

LOW SPEED INLINE CAP STERILIZATION – INNER SURFACE

INNOCAP ESSENTIAL®

ULTRA-CLEAN FILLING OF

CHILLED

Juices, dairy liquids and alternatives, liquid egg.

AMBIANT

Water and water +, preserved soft drinks, sensitive CSDs, low alcohol beverages, kombucha, sauces, syrups.

APPLICATIONS

- FLAT AND SPORT CAPS (plastic, alu)
- LONG NECK, CROWNS, T-CORK
- TWIST-OFF

STANDARD CAP SIZE: 28-55 mm

FEATURES

- 1 Air cooled Flash lamp @ max 0,8 hz
- Compact and easy to integrate on new or existing line
- Dry and non chemical
- Low energy consumption < 1 kw
- No heating time
- Indexing system for first caps
- Quartz break detection (option)
- Efficiency >>> UVC on molds

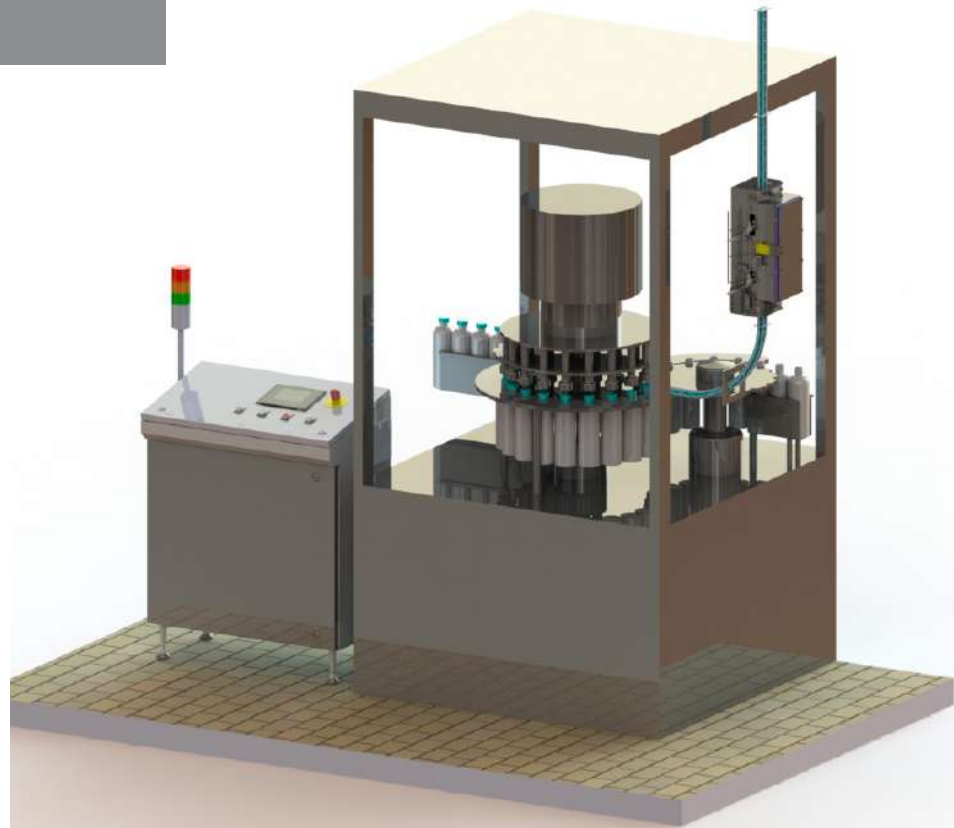

INNOVATIONS

- Hygienic design, fully cleanable cap chute, COP-able, IP 66 cabinet
- Installation of guiding channel on copper possible previous to full installation
- Light weight, unit may be carried by cap chute
- Patented design

PERFORMANCE

3 Log-Red on molds (Class IV VDMA)
Up to 18 000 bph



PERFORMANCES

- Class IV VDMA
- > 3 Log-Red on *Aspergillus brasiliensis* or *Penicillium rubens*
- Sterilization of surface in contact with product
- Factory and site microbial qualification possible

PRODUCT RANGE

- Combination possible with preform or bottle neck sterilization
- 2 lamp version for larger diameter
- May be offered as OEM kit

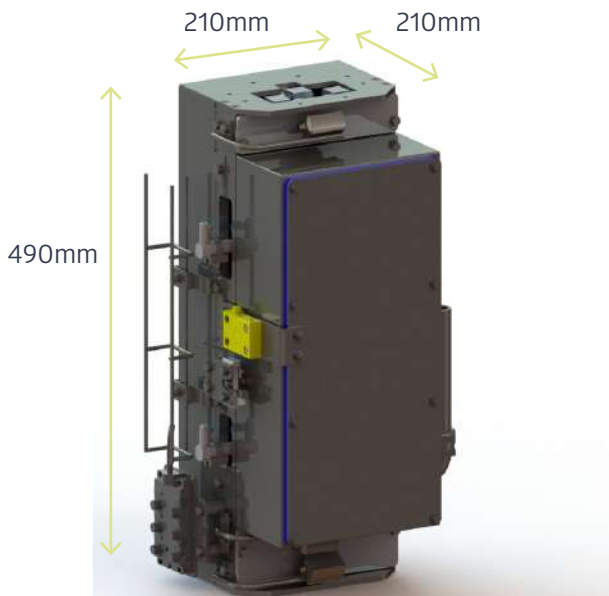

INNCAP ESSENTIAL closed

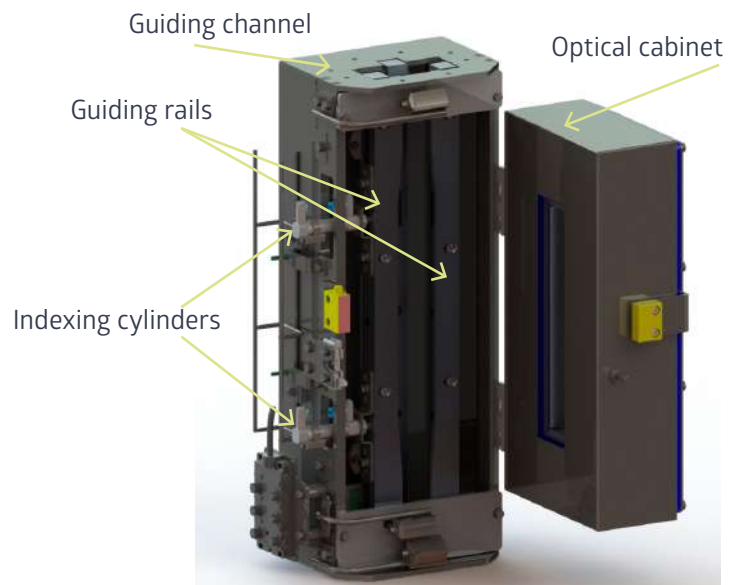

INNCAP ESSENTIAL (opened)

TECHNICAL AND FINANCIAL DATA

	Essential
Lamp length	205 mm
Guiding channel height	490 mm
Business case cap Ø 40 mm	12 000 bph, kwh @0,30 €
Lamp change every	2.100 h
Average power	< 0,4 Kw
TCO @ 5000 h *	3000 €
Opex for 1 M Caps*	51 €
Cabinet + channel L x l x H and weight	210 x 210 x 490 mm / 16,5 kg
Electric panel dimensions and weight	830 x 460 x 1050 mm / 110 kg
Lamp lifetime 5 M flashes	

*Estimation Sept 2022